

nbn™ Connection Guide - Fibre to the Node (FTTN)

STEP 1 - Locate the wall socket in your home

Find the telephone wall socket in your home. They're most commonly found in the main living room space or bedrooms, but sometimes they're in the kitchen area. It should look something like the photo below. Make a note of all the sockets in your home, even ones that may be in non-ideal locations such as bedrooms.

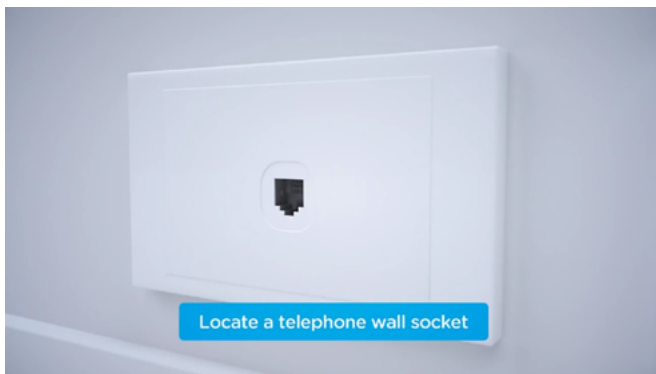

If your home has an older style wall socket shown below (typically the plug is a yellow square with 3 prongs), you'll need to purchase a Jackson adapter that allows you to plug in a modern RJ11 phone cable. These adapters can be purchased at all most electronics and computer stores.



IMPORTANT: If you are porting your existing landline telephone number to an nbn™ VoIP service and you need to keep using your landline phone at the premises until the port is completed (porting can take up to six (6) weeks), you will need to purchase and connect a VDSL in-line filter/splitter to connect your

phone and VDSL. A VDSL splitter can be purchased at most major electronics stores.

STEP 2 - Connect your VDSL modem

Disconnect all devices in your home such as telephones, modems, fax machines or anything else that is plugged into a telephone wall socket. It is very important that you have no other devices plugged into sockets in your home.

Take your modem/router's power supply cable and use it to connect your modem/router's power port to an electrical outlet. Switch the power point on. Plug the included grey telephone cable that comes with your VDSL modem into the DSL port on the back of your VDSL modem. Plug the other end of the telephone cable into your wall socket. The setup should look like the below image once completed.

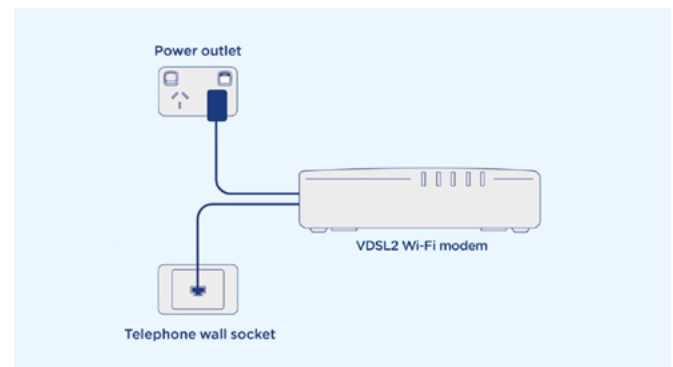

Plug the included grey telephone cable that comes with your VDSL modem into the DSL port on the back of your VDSL modem. Plug the other end of the telephone cable into your wall socket. You will now need to wait for the DSL light on your modem to turn solid - this may take up to 15 minutes. **DO NOT UNPLUG THE DEVICE DURING THIS TIME.**

If the DSL light on your VDSL modem does not turn solid after 15 minutes and you have more than one socket in the home, please plug your VDSL modem into other sockets in your home, and turn the power on and off once plugged in. Leave your VDSL modem plugged into each socket for up to 15 minutes until the DSL light on the modem turns solid.



If the DSL light on your VDSL modem does not turn solid green after 15 minutes and you have tried to connect this on ALL phone wall sockets in your home, please contact our support team for further troubleshooting.

Connecting your modem/router - nbn™ Fibre to the Node (FTTN)

OPTION 1: I chose the Barefoot supplied modem/router

Your Barefoot Communicate modem comes pre-configured and does not require any setup to connect your nbn™ Fibre to the Node (FTTN) service. Simply ensure the supplied grey telephone cable is plugged in - one end needs to be plugged into the grey DSL port on the back of your modem, and the other end to the wall socket in your premises. Ensure the power cable is plugged into the back of your modem and is connected to a power outlet and switched on.



Your Barefoot modem/router will begin broadcasting Wi-Fi as soon as it is plugged into power, turned on and has finished booting up. You can then connect your devices such as computers, phones and tablets via Wi-Fi.

The modem's Wi-Fi name and password is printed on a separate card included with the modem. The Wi-Fi name and password is also shown on the bottom of the modem as "WiFi Network Name" and "WiFi Password" for both the 2.4GHz and 5GHz networks.



If you have a computer nearby that you would like to connect via Ethernet, take another Ethernet cable and plug one end into any one of the modem's yellow Ethernet ports (labelled LAN).

If you have issues connecting your Barefoot supplied modem/router, please contact our support team at support@barefoottelecom.com.au or 1300 017 622 for further troubleshooting.

OPTION 2: I chose BYO modem/router

Your BYO modem/router will need to be configured with your new Barefoot Communicate nbn™ details to work. You will require a VDSL modem to use this service

1. First, ensure the supplied telephone cable with your modem/router (this is usually grey or white) is plugged from the DSL/VDSL port on the back of your BYO modem, into the wall socket in your premises. Ensure the power cable is plugged into a power outlet and switched on.
2. You will now need to connect your BYO modem/router to your device. You'll need a computer, laptop, tablet or smartphone that is connected to your BYO modem/router via Ethernet or Wi-Fi.

3. Once you have connected your device to your BYO modem/router, open the web browser on your connected device and type in your modem/router's default gateway/admin IP address in the address bar. This will be printed on the bottom or back of your modem depending on the make and model. Some of the most common addresses are 192.168.1.1, 192.168.20.1, 10.1.1.1 and 10.0.0.138.

4. Once you have accessed the gateway of your modem/router, you may see a login page. If there's a username field, the default username will almost always be admin (it may even already be filled in). The default password is typically admin or password. If you can't log in with these settings, please check the manufacturer's website for your BYO modem/router's default login settings. If your BYO modem router is secondhand or you have used it previously, it may have custom login details set. If you need to, you can factory reset the modem router to return it to the default settings.

5. From here, it gets a little tricky to offer general advice for all BYO modem/routers. The layout of modem/router settings pages can vary greatly for each different modem. If you get stuck or it is not clear where you should change your Internet settings, you need to check the manufacturer's website for support information. Ideally, your modem will have a Setup Wizard or Quick Setup that will run automatically the first time you log in to the settings, or there'll be a fairly obvious button to launch it.

6. The Setup Wizard should run you through entering the required broadband settings, step by step. The most important settings are the following:

- Encapsulation or Connection Type
- Must be set to **PPPoE**

- Connection Mode/Access Type/Service Type
- Must be set to **VDSL**

This will then allow you to enter your username (sometimes called Login) and password which are supplied in your Barefoot Welcome Letter email.

7. After completing the Setup Wizard and saving your settings, give the modem some time. Some modem routers reboot automatically after every new configuration, while others simply need a few minutes to apply the settings. Take a look at the lights on your modem router. Most should now be green, blue, purple or another "positive" colour. Many modem routers have lights that flash to indicate connection activity, so you shouldn't be concerned if any lights are flashing unless the manufacturer's support information specifically advises that flashing lights indicate a problem.

8. Hop on one of your computers or Wi-Fi devices and try to visit a website. If it works, your nbn™ Internet is up and running! If you have issues connecting, please contact our support team at support@barefoottelecom.com.au or 1300 017 622 for further troubleshooting.